

# ADDITIONAL INSTRUCTIONS

## 1. Remove Steering Limiter Bolt

20 mm or equivalent wrench required.

1. Steering Limiter Bolt is located behind the left rear ChildPod® wheel. Remove by turning counterclockwise with wrench.
2. Press Plastic Plug (included in package) into hole.

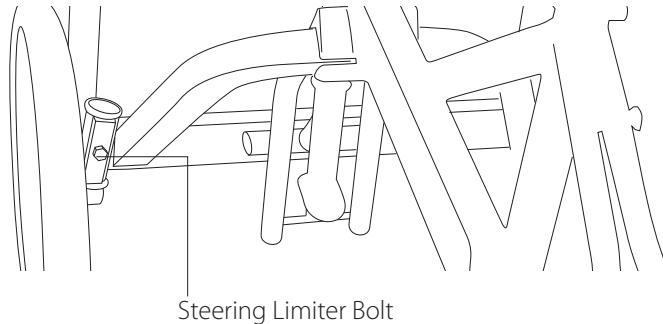

## 2. Troubleshooting LeaderLink® Braking

### NOTE

Section 9.7.1: Adjust Brake Hub Barrel Adjustor in the Zigo® Leader™ Owner's Manual is incorrect. The Brake Lines are reversed.

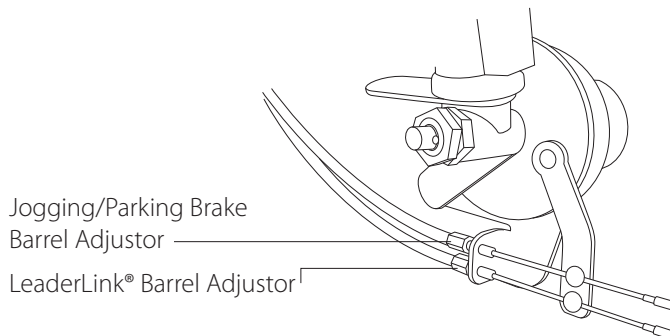

## 2.1 Check Brake Lines at hub

### 2.1.1 ChildPod® Rear Wheels may not install due to Brake Arm engagement during shipment

During shipping, the Brake Arm may engage and push the Cable Housing out of its Barrel Adjustor. End of Cable Housing must insert fully into its Barrel Adjustor to function properly.

#### Incorrect

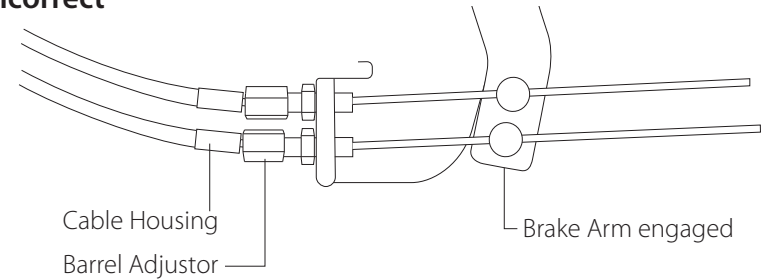

#### Correct

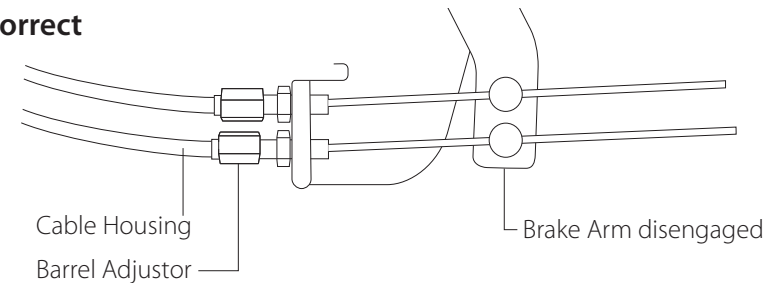

## 2.2 Adjusting Barrel Adjustors

### 2.2.1 ChildPod® Rear Wheels may not install due to excess Brake Arm tension

If the ChildPod® Rear Wheel does not install due to excess Brake Arm tension, Barrel Adjustors should be moved inward to bring the Brake Arm in.

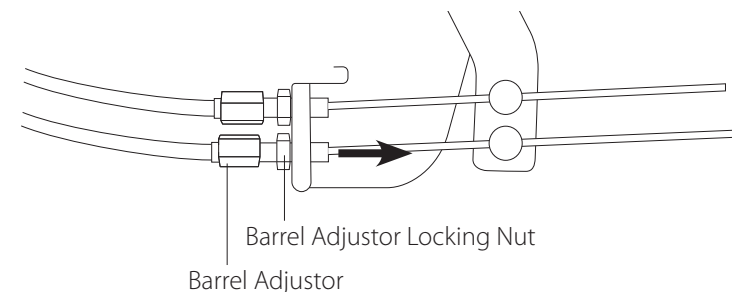

1. Release top and bottom Barrel Adjustor Locking Nuts to allow for Barrel Adjustor movement. Turn counterclockwise.
2. Move top and bottom Barrel Adjustors inward by turning clockwise. Turn both Barrel Adjustors evenly and test for Rear Wheel fit every 2 or 3 turns.
3. After installing Rear Wheel, turn Barrel Adjustor Locking Nut clockwise to lock Barrel Adjustor in place.

### 2.2.2 Front Brake Lever (left lever on Cycle) and Brake Arm may not spring back to unengaged position

This occurs when there is slack in any of the Brake Lines. Excess slack is most likely to occur on ChildPod® between base of LeaderLink® Post (located near Steering Interface) and hub.

1. Uncouple Cycle from ChildPod®. Pull back Brake Arms to ensure that they have each returned to the unengaged position.
2. Turn ChildPod® on its side. Check all Brake Lines for slack in Cable Housing.
3. Once the slack Brake Line is identified:
  - a. Turn its Barrel Adjustor Locking Nut counterclockwise to allow for Barrel Adjustor movement.
  - b. Remove Brake Line slack by turning Barrel Adjustor of slack Cable Line counterclockwise. Do not overtighten Barrel Adjustor. See Section 2.2.1 if you overtighten.
  - c. Lock Barrel Adjustor Locking Nut by turning clockwise.
  - d. Couple Cycle to ChildPod® and check Front Brake lever action.

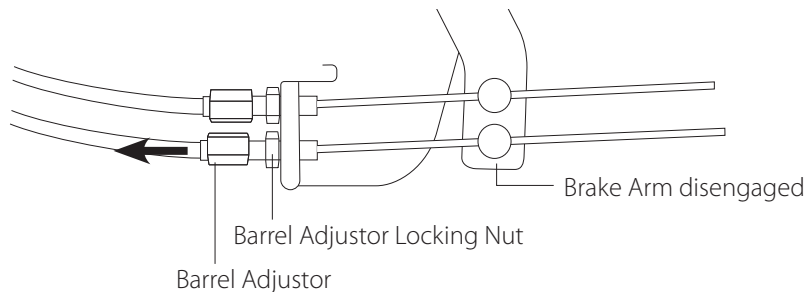

## 3. Setting up the Cycle - Additional Items

### 3.1 Install the Front Cantilever Brake Cable Yoke

### 3.2 Setting up the Front Cantilever Brake

### 3.3 Installing the LeaderLink® Post

1. Remove all packaging materials from Cycle.
2. Insert LeaderLink® Post into Cycle head tube located in center of Stem Clamp.

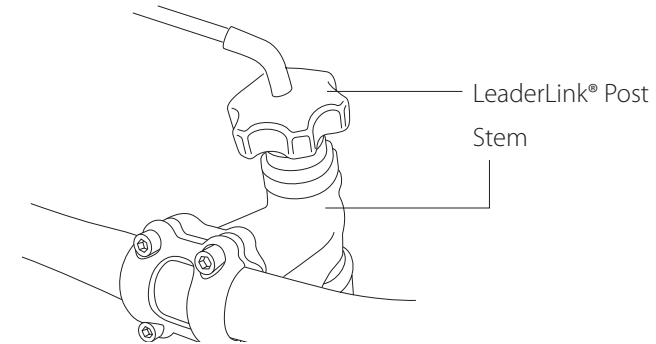

### 3.4 Installing Reflectors

#### CAUTION

Always make sure to use the reflectors in their correctly mounted orientation for best safety and visibility.

## 4. Restraint Harness

Ensure that Lap Belts are properly configured for either one or two children. See Section 8.1 in the Zigo Leader Owner's Manual.